



目录

Contents

Unit 1 Greetings

Lesson 1	Hello!	1
Lesson 2	How are you?	3
Lesson 3	Nice to meet you.	5
Lesson 4	Again, please!	7

Unit 2 Introduction

Lesson 1	This is Wang Hong.	9
Lesson 2	What's your name?	11
Lesson 3	She's my friend.	13
Lesson 4	Again, please!	15

Unit 3 Family

Lesson 1	This is my mother.	17
Lesson 2	He's my grandpa.	19
Lesson 3	She's a doctor.	21
Lesson 4	Again, please!	23

Unit 4 Body

Lesson 1	This is my head.	25
Lesson 2	I have a face.	27
Lesson 3	I have two eyes.	29
Lesson 4	Again, please!	31

听力音频可登录山东科学技术出版社官网下载或关注山东科学技术出版社微信公众号在线收听。



期中测试 33

Unit 5 Classroom

Lesson 1 This is my desk. 36
Lesson 2 I have a new pen. 38
Lesson 3 What's this? 40
Lesson 4 Again, please! 42

Unit 6 Colours

Lesson 1 It's red. 44
Lesson 2 It's red and yellow. 46
Lesson 3 I like green. 48
Lesson 4 Again, please! 50

Unit 7 Numbers

Lesson 1 How many colours? 52
Lesson 2 How many books do you have? 54
Lesson 3 How old are you? 56
Lesson 4 Again, please! 58

期末测试 60

参考答案 63

听力原文 65



Unit 7 Numbers

Lesson 1 How many colours?



I. Listen and tick or cross. (听录音, 判断所听内容与图片是否相符, 相符的填“√”, 不相符的填“×”。)

() 1.



() 2.



() 3.



() 4.



() 5.



II. Listen and choose. (听录音, 选出与所听内容相符的图片。)

() 1. A.



B.



() 2. A.



B.



() 3. A.



B.

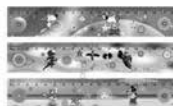

() 4. A.



B.



() 5. A.



B.





III. Read, count and colour. (读一读, 按要求给相应数量的学习用品涂色。)

1. three red erasers

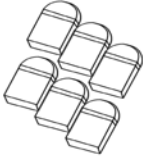

2. four red rulers

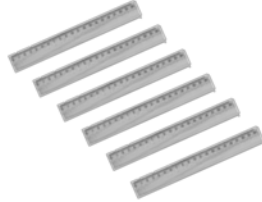

3. two green books

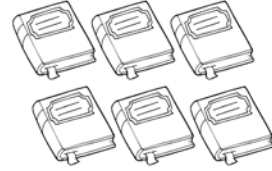

4. one blue pencil

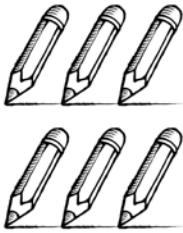

5. five red schoolbags

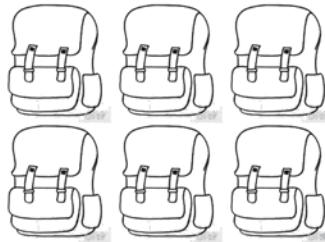

IV. Read, count and choose. (读一读, 数一数, 选一选。)

A. One B. Two C. Three D. Four E. Five

1. —How many rulers?

—_____.



2. —How many pencils?

—_____.



3. —How many desks?

—_____.



4. —How many colours?

—_____.



5. —How many chairs?

—_____.





Lesson 2 How many books do you have?



I. Listen and number. (听录音, 标序号。)



()



()



()



()



()



II. Listen and write. (听录音, 写出下列小汽车的车牌号。)

1.



2.



3.



4.



5.



III. Read and match. (请将下列门牌号与对应的英文单词连线。)

1.



A. six one two

2.



B. seven two one

3.



C. nine one four

4.



D. eight two three



IV. Read, choose and judge. (阅读对话, 按要求完成下列题目。)

Lucy: Good morning, Mary!

Mary: Good morning, Lucy! Look! I have a red schoolbag.

Lucy: It's nice. I have a new pencil-case.

Mary: What colour is it?

Lucy: It's green and yellow.

Mary: How many pencils do you have?

Lucy: Let's count. One, two, three, four, five, six, seven. I have seven pencils.

How many pencils do you have?

Mary: I have three. But (但) I have seven books.

(一) 读一读, 选一选。

1. Mary has (有) a nice _____. Lucy has a new _____.

A.



B.



C.



2. —What colour is the schoolbag? —It's _____.

A. green

B. red

C. blue

(二) 判断正 (T) 误 (F)。

() 3. Lucy has a yellow pencil-case.

() 4. Mary has seven pencils.

() 5. Mary has seven books.



Lesson 3 How old are you?



I. Listen and number. (听录音, 标序号。)



()



()



()



()



()



II. Listen and tick or cross. (听录音, 判断所听内容与图片是否相符, 相符的填“√”, 不相符的填“×”。)

1.



()

2.



()

3.

136

()

4.



()

5.

189

()



III. Look, read and choose. (看图, 读句子, 选择正确的选项完成对话。)

A. Thank you.

B. I'm nine.

C. I have six books.

D. Three.



IV. Look and learn. (看一看, 学一学。)

同学们, 英语字母也被广泛应用于其他学科, 比如下面的平面坐标图、三维坐标图及地理坐标图。请同学们找一找图上的英文字母, 上网查询一下它们代表的含义, 并与同学交流一下。

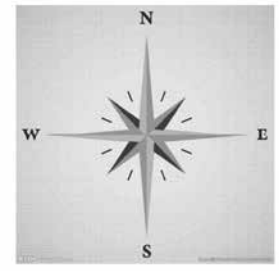
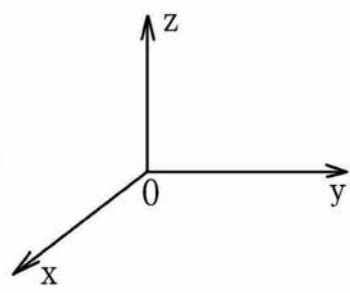
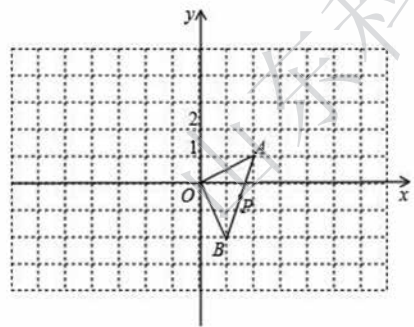



Lesson 4 Again, please!



I. Listen and match. (听录音, 判断下列小朋友的年龄并与对应的生日蛋糕连线。)

1.



2.



3.



4.



5.



A.



B.



C.



D.



E.



II. Listen and choose. (听录音, 选出与所听内容相符的图片。)

() 1. A.

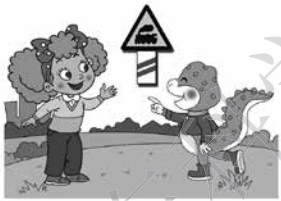

B.



() 2. A.

Uu

B.

Vv

() 3. A.

Xx

B.

Yy

() 4. A.



B.



() 5. A.



B.





III. Read and choose. (读一读, 选一选。)

- () 1. —How many books do you have?
—I have _____.
A. ten B. blue C. brother
- () 2. —How many colours?
— _____
A. Let's play. B. Let's go. C. Let's count.
- () 3. —How many _____ do you have?
—I have two.
A. eraser B. an eraser C. erasers
- () 4. —How many colours?
— _____
A. Nine. B. Seven. C. Five.
- () 5. —How _____ are you?
—I'm ten.
A. much B. old C. many



IV. Read and choose. (阅读短文, 选择正确答案。)

Hello! My name is Mike. I'm eight. I have two brothers. I have two sisters. Look! I have a new green desk and a new green chair. I have an orange schoolbag. I have a red pencil-case. I have three red pens. I have six red pencils. I like red.

- () 1. —What's your name? — _____
A. My name's Jenny. B. My name's Mike. C. My name's Bob.
- () 2. —How old are you? — _____
A. I am 10. B. I am 9. C. I am 8.
- () 3. —How many pencils do you have? — _____
A. I have three pencils. B. I have four pencils. C. I have six pencils.
- () 4. —How many sisters do you have? — _____
A. One. B. Two. C. Three.
- () 5. —What colour do you like? — _____
A. I like red. B. I like green. C. I like orange.

期末测试

听力部分

I. Listen and choose. (听录音, 选出你所听到的字母或单词, 将正确选项的序号填在题前的括号内。)

- | | | |
|------------------|-----------|------------|
| () 1. A. Ll | B. Mm | C. Nn |
| () 2. A. Uu | B. Qq | C. Ww |
| () 3. A. two | B. three | C. ten |
| () 4. A. ruler | B. pen | C. pencil |
| () 5. A. mother | B. father | C. brother |

II. Listen and number. (听录音, 标序号。)

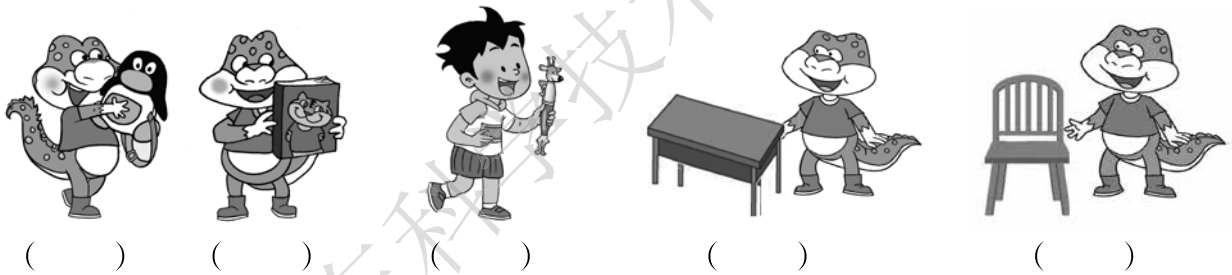

() () () () ()

III. Listen and tick. (听录音, 选择图片, 在相应的图片下打“√”。)

1. A. M m B. N n

() ()

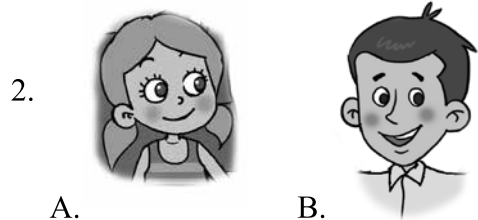

A. () B. ()

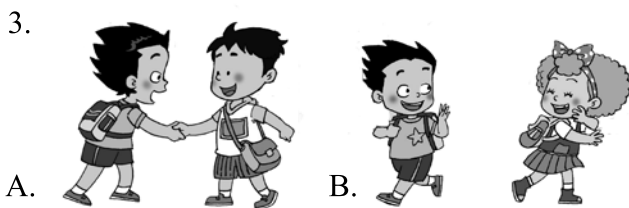

A. () B. ()

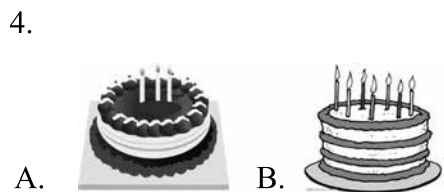

A. () B. ()

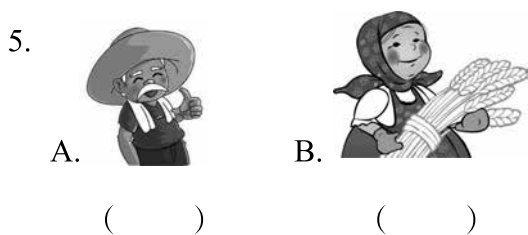

笔试部分

IV. Look and choose. (认识小丑的身体部位, 将正确选项的序号填入相应的圆圈内。)

A. foot B. nose C. mouth D. hand E. arm

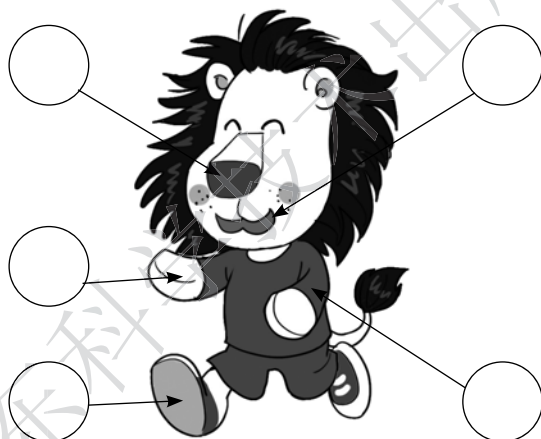

V. Look and choose. (看一看, 选一选, 将答案序号填在横线上。)

A. I'm nine. B. Good afternoon! C. Three.
D. Hi! I'm Jenny. E. Nice to meet you, too.



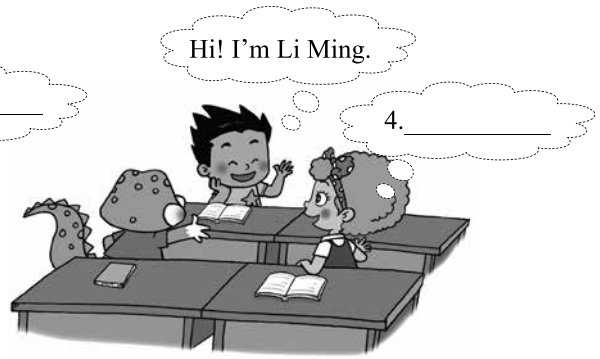

VI. Read, choose and judge. (阅读短文, 按照要求完成下列题目。)

Hello! I'm Jenny. I'm nine. I have a happy family. My mother is a teacher. My father is a doctor. I love (爱) my family. I have a good friend. She's Wang Li. She's ten. Look! I have a new schoolbag. It's red. I like red.

(一) 读一读, 选一选。

() 1. —How old are you, Jenny?

— _____

A. I'm nine.

B. I'm ten.

C. I'm eight.

() 2. —What colour is your schoolbag, Jenny?

— _____

A. It's blue.

B. It's red.

C. It's green.

(二) 判断正(T)误(F)。

() 3. Wang Li is nine.

() 4. Jenny has (有) a good friend.

() 5. Jenny's mother is a doctor.



期中测试

听力部分

- I. 2 1 4 3 5 II. B A B B A
III. B B B A A

笔试部分

- IV. 略 V. C D E A B
VI. B B A C B

Unit 5 Classroom

Lesson 1 This is my desk.

- I. 2 3 1 II. B A A A B
III. 1. C 2. A 3. B IV. C B D A

Lesson 2 I have a new pen.

- I. B B B A II. $\times \checkmark \times \checkmark \times$
III. A C D B IV. 略

Lesson 3 What's this?

- I. 4 3 2 5 1 II. B A A B A
III. D B A C IV. B C E A D

Lesson 4 Again, please!

- I. 3 1 2 5 4 II. $\checkmark \times \times \checkmark \checkmark$
III. B A A C C IV. B E A D C
V. A A A B B A A

Unit 6 Colours

Lesson 1 It's red.

- I. 黄色 红色 蓝色 绿色
II. 1. C 2. D 3. A 4. B
III. B C D A IV. 略

Lesson 2 It's red and yellow.

- I. 2 3 1
II. B C E A D
1. 涂蓝色和红色 2. 涂白色 3. 涂绿色
4. 涂黄绿相间 5. 涂白红相间
III. 略
IV. B C A

Lesson 3 I like green.

- I. 略
II. 红色 蓝色 黄色 绿色 黑色
III. 1. D 2. B 3. A 4. E 5. C
1. 红色 2. 黑色 3. 绿色 4. 蓝色
5. 橙色
IV. T F F T T

Lesson 4 Again, please!

- I. B C B A C II. $\times \checkmark \times \checkmark$
III. 略 IV. B A B C C

Unit 7 Numbers

Lesson 1 How many colours?

- I. $\times \checkmark \checkmark \times \checkmark$ II. A B A B B
III. 略 IV. C D A B E

Lesson 2 How many books do you have?

- I. 3 1 5 4 2
II. 7 1 6 5 8 3 6 2 4 9 3 5 4 9 8
III. 1. D 2. C 3. A 4. B
IV. 1. A C 2. B 3. F 4. F 5. T

Lesson 3 How old are you?

- I. 3 1 4 5 2 II. $\times \checkmark \times \checkmark \times$
III. C A B D IV. 略

Lesson 4 Again, please!

- I. 1-E 2-D 3-C 4-A 5-B
II. A B B A B
III. A C C B B
IV. B C C B A

期末测试

听力部分

- I. C B C A A II. 2 4 1 5 3
III. B B A A B

笔试部分

- IV. 略
V. B E A D C
VI. A B F T F



3. —What colour do you like, Li Ming? —I like blue.
 4. —What colour do you like, Guo Yang?
 —I like red and white.
 5. —What colour do you like, Wang Hong?
 —I like black and orange.

II . Listen and colour.

1. —What colour do you like, Danny?
 —I like red. The pencil-case is red.
 2. —What colour do you like, Danny?
 —I like blue. The pen is blue.
 3. —What colour do you like, Danny?
 —I like yellow. The ruler is yellow.
 4. —What colour do you like, Danny?
 —I like green. The schoolbag is green.
 5. —What colour do you like, Danny?
 —I like black. The book is black.

Lesson 4 Again, please!

I . Listen and choose.

1. —What colour is the ruler? —It's green.
 2. —What colour are they? —They're black, red and yellow.
 3. —What colour is the pencil-case?
 —It's blue and orange.
 4. —What colour is the pencil? —It's red.
 5. —What colour is it? —It's white and blue.

II . Listen and tick or cross.

1. —What colour is it? —It's red and yellow.
 2. —What colour do you like? —I like orange.
 3. I have a new eraser. It's yellow.
 4. This is my pencil-case. It's blue. I like blue.

Unit 7 Numbers

Lesson 1 How many colours?

I . Listen and tick or cross.

- 1.—How many pencils? —Five.
 2.—How many erasers? —Three.
 3.—How many rulers? —Two.
 4.—How many pencil-cases? —Four.
 5.—How many pens? —One.

II . Listen and choose.

1. —How many pencils? —Three.
 2. —How many erasers? —Four.
 3. —How many rulers? —One.
 4. —How many schoolbags? —Five.
 5. —How many chairs? —Two.

Lesson 2 How many books do you have?

I . Listen and number.

1. I have five pencils. 2. I have seven desks.
 3. I have six books. 4. I have ten erasers.
 5. I have eight rulers.

II . Listen and write.

1. seven one six 2. five eight three 3. six two four
 4. nine three five 5. four nine eight

Lesson 3 How old are you?

I . Listen and number.

1. —How old are you? —I'm three.
 2. —How old are you? —I'm nine.
 3. —How old are you? —I'm five.
 4. —How old are you? —I'm four.
 5. —How old are you? —I'm seven.

II . Listen and tick or cross.

1. six two one 2. eight nine eight 3. one seven two
 4. one one nine 5. one six four

Lesson 4 Again, please!

I . Listen and match.

1. —How old are you? —I'm five.
 2. —How old are you? —I'm nine.
 3. —How old are you? —I'm eight.
 4. —How old are you? —I'm seven.
 5. —How old are you? —I'm six.

II . Listen and choose.

1. —How many colours? —Four.
 2. —What's this? —It's V.
 3. —What's this? —It's Y.
 4. —How many pencils do you have? —Let's count.
 5. —How old are you? —I'm seven.

期末测试

I . Listen and choose.

1. Nn 2. Qq 3. ten 4. ruler 5. mother

II . Listen and number.

1. I have a pen. 2. I have a schoolbag.
 3. I have a chair. 4. I have a book. 5. I have a desk.

III . Listen and tick.

1. It's N. 2. This is my brother. 3. Nice to meet you.
 4. —How old are you? —I'm three.
 5. This is my grandma. She's a farmer.